

FLEX-MIX™ PILOT MIXER



Application

The Flex-Mix™ Pilot Mixer is a flexible skid mounted mixer specially designed for high shear mixing by means of the rotor/stator principle in combination with the pilot scale mixing represented by the different working methods of the APV Flex-Mix™ program:

- Flex-Mix™ Instant. Vacuum mixing for low viscous products. External recirculation.
- Flex-Mix™ Multiverter. Mixing with or without vacuum and mixing under pressure (high temperature) for medium and high viscous products. External recirculation.
- Flex-Mix™ Liquiverter. Atmospheric mixing for low viscous products. Internal recirculation.

Typical applications include

- Mixing of products with low and medium/high viscosities
- Operating under vacuum/atmospheric pressure for incorporation of dry or semi solids into liquid
- Chopping of solids
- Heating/cooling of blended products
- Dispersion
- Reconstitution
- Rehydration
- Re-establishment of soluble products

The Flex-Mix™ Pilot Mixer is especially suitable for product formulations requiring a wide range of ingredients including liquids, dry powders, soluble pastes, coarse grinds, and solids.

Capacity

- 100 – 140 L

Operation

The rotor/stator mixer pump generate a flow, which can be recirculated internally in the mixer tank, or it can be recirculated back to the tank in an external loop. The agitator can be active for high viscous products, or it can be removed in low viscous applications. In vacuum configurations the dry matter (powder) can be sucked into the tank below the liquid surface.

A vortex sucks both powder and liquid down toward the rotor/stator mixer pump. The vortex will also ensure that powders and particles being added through the top of the tank will be drawn down into the mixer pump. In both the mixer pump rotor and the surrounding stator, high shear forces and turbulence are created ensuring effective and homogeneous mixing.

For high viscous products, the scraper blade agitator can run to create additional mixing and to remove product film from the side wall of the tank. For external recirculation of high viscous products, a positive displacement booster pump is included.

General

- All product contacting areas are made of stainless steel AISI 316/ DIN 1.4401
- Seal material in EPDM or FPM (Viton), FDA quality
- Interior surfaces in 3A finish, Ra 0.8 micron with polished welds
- Sanitary design for CIP cleaning
- Operator interface screen for control. Partly manually operated.

Tank design

- Circular tank with a cone shaped bottom
- Pressurized (multi duty) or full vacuum tank (basic)
- Heating/cooling jacket on tank and wall and with insulation of the outer jacket
- Top mounted liftable manway cover with safety lock (multi duty)
- Top mounted manway cover with safety lock (basic)
- Side mounted inlet for minor ingredients
- Bottom mounted inlet for powder suction
- Bottom mounted mixer outlet
- Vacuum connection on manway
- Top mounted scraper blade agitator (multi duty)
- One CIP inlet branch, Ø25 mm with rotary spray ball

Bottom mixer

- A vertically mounted mixer pumping unit with a variable speed control, 7.5 kW IEC motor, 2 poles
- 2 stator types (exchangeable) for internal or external mixing set up
- Double mechanical shaft seal. Product side in SiC/SiC and atmospheric side in SiC/C

Top entry agitator (Multi duty)

- Top mounted anchor type agitator
- Variable speed controlled 2.2 kW motor with scraperblades acting on the side wall
- Removable for low viscous products (instant duty)
- Double mechanical shaft seal. Product side in SiC/SiC and atmospheric side in SiC/C

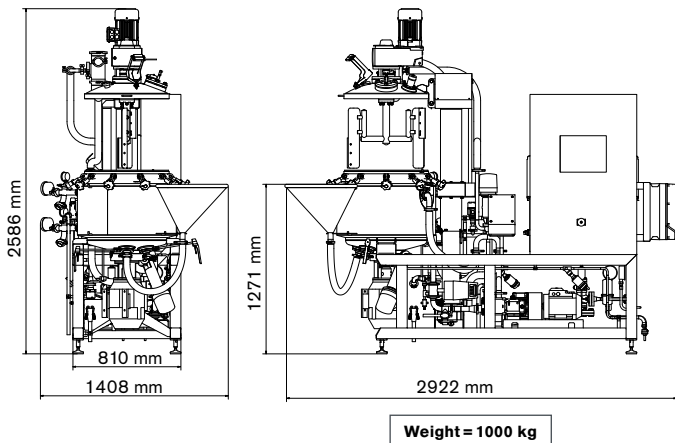

The Flex-Mix™ Pilot Mixer includes

	MULTI DUTY PILOT MIXER	BASIC PILOT MIXER
Covers Flex-Mix™ Liquiverter	x	x
Covers Flex-Mix™ Instant	x	x
Covers Flex-Mix™ Multiverter	x	
140 L tank	x	x
High shear mixer pump (rotor/stator principle)	x	x
Vacuum system	x	x
Powder inlet and hopper	x	x
Jacket for heating and cooling	x	x
Control panel	x	x
Pressurized tank and full vacuum tank	x	
Full vacuum tank only		x
Manual manway		x
Actuator activated lifting system for manway	x	
System for direct steam injection	x (option)	
Positive displacement pump	x	

	TANK		INLINE MIXER		VACUUM PUMP			VALVES		
	Tank volume	Pressure rating	Inline mixer size	Shear rate @50 Hz	Motor		Data @500mbar Abs			
Type Flex-Mix™ Pilot Plant	L	Bar	mm	s ⁻¹	Power kW	Speed @50Hz RPM	Air capacity m ³ /h	Motor @50Hz kW	Sealing water @no recovery m ³ /h	Min/max air pressure Bar
Basic unit	100-140	Full vacuum to 0.5	Ø130	25000	7.5	1450	50	2.2	0.9	6/8
Multi duty unit	100-140	Full vacuum to 4								

SPX FLOW, Inc. reserves the right to incorporate our latest design and material changes without notice or obligation. Design features, materials of construction and dimensional data, as described in this bulletin, are provided for your information only and should not be relied upon unless confirmed in writing. Please contact your local sales representative for product availability in your region. For more information visit www.spxflow.com.

The green “>” and “X” are trademarks of SPX FLOW, Inc.